

# BRAKE SYSTEM

1990 Volvo 740

1989-90 BRAKES  
Volvo - Disc

240 Series, 740 Series, 760 Series

## DESCRIPTION

All models use front and rear disc brakes. Three makes of calipers are used: ATE, Bendix (DBA) and Girling. Service brakes are hydraulically-operated by a tandem master cylinder and vacuum power brake unit. Each rear brake line has a pressure valve to prevent rear wheel lock-up. Parking brake is mechanically operated, using rear wheel disc rotor internally-mounted brake shoes.

NOTE: For information on Volvo anti-lock brake system, see appropriate article for 740 and 760 series:

- \* ANTI-LOCK BRAKE SYSTEM - 1989
- \* ANTI-LOCK BRAKE SYSTEM - 1990

## BRAKE BLEEDING

NOTE: For vehicles with ABS, see appropriate article for 740 and 760 series:

- \* ANTI-LOCK BRAKE SYSTEM - 1989
- \* ANTI-LOCK BRAKE SYSTEM - 1990

## BLEEDING PRECAUTIONS

1) On all models equipped with diagonal split hydraulic system, bleed either rear wheel first, then opposite front. Repeat procedure on other side (circuit).

2) On all models equipped with load sensing proportioning valve, bleed valve before bleeding brakes. If master cylinder is equipped with a bleed screw, bleed it first.

## MANUAL BLEEDING

1) Exhaust vacuum from power unit by depressing brake pedal several times.

2) Fill master cylinder. Install a clear vinyl bleeder hose onto first bleeder valve to be serviced. See the BLEEDING SEQUENCE table below. Place other end of hose in clean transparent container.

3) Partially fill container with clean brake fluid so end of hose is submerged in fluid. Open bleeder valve 1-2 turns. Slowly depress brake pedal through its full travel.

4) Close bleeder valve and release pedal. Pump pedal several times and push air toward wheel cylinders. Repeat procedure until flow of brake fluid is clear and shows no sign of air bubbles. Proceed to next bleeder valve.

NOTE: Check fluid level in master cylinder frequently during bleeding sequence.

## PRESSURE TANK BLEEDING

1) Exhaust vacuum from power unit by depressing brake pedal

several times.

2) Clean the master cylinder cap and surrounding area, then remove cap. With pressure tank at least 1/2 full, connect tank to the master cylinder using proper adapter(s).

3) Attach bleeder hose to first bleeder valve to be serviced. See the BLEEDING SEQUENCE table below. Place other end of hose in clean transparent container. Partially fill container with clean brake fluid, until end of hose is submerged in fluid.

4) Open release valve on pressure bleeder. Open bleeder valve 1-2 turns, noting fluid flow. When fluid flowing in to container is clear and free of air bubbles, close bleeder valve securely.

5) Finish bleeding system in the same manner using correct sequence. Remove pressure tank from master cylinder and check fluid level of master cylinder reservoir.

#### BLEEDING SEQUENCE TABLE (1)

---

| Application     | Sequence       |
|-----------------|----------------|
| 240 .....       | LF, RF, LR, RR |
| 740 & 760 ..... | RR, LR, RF, LF |

(1) - On calipers with 3 bleeder valves, open all valves simultaneously.

---

## ADJUSTMENTS

### BRAKE PEDAL HEIGHT

Brake pedal height should be equal to clutch pedal height. To adjust, loosen lock nut, remove cotter pin and turn push rod until pedal height is equal. Replace cotter pin and tighten lock nut. Pedal travel should be 6-7" (150-170 mm). Pedal travel can ONLY be measured during brake bleeding operation. See BRAKE BLEEDING in this article.

### PARKING/EMERGENCY BRAKE

#### 740 Series & 760 Series

Remove cover at rear of center console. Remove adjusting screw by carefully tapping on locking sleeve spring collar with a hammer and screwdriver. Adjust cable so that parking brake is fully applied when lever is pulled 3-5 notches. Install cover.

#### 240 Series

1) Remove center console rear ashtray. Working through ashtray hole, loosen parking brake cables adjusting screw until cables are slack. Raise and support rear of vehicle. Remove rear wheels. Align hole in disc/parking brake drum with inside starwheel adjuster.

2) Tighten starwheel until drum can barely be rotated by hand. Back off adjuster until drum just rotates freely (no drag). Install rear wheels. Tighten parking brake cable adjusting screw until parking brake is fully applied when lever is pulled 2-8 notches. Install ashtray and lower vehicle.

### STOPLIGHT SWITCH

Adjust switch so brake lights come on when pedal is depressed about 1/2" (13 mm).

## REMOVAL & INSTALLATION

## DISC PADS

NOTE: Use Remover (2917) to remove brake pads (if necessary).

### ATE Pads

1) Raise and support vehicle. Mark position of wheel in relation to hub for reassembly reference. Remove tire and wheel. Using a drift and hammer, remove the brake pads retaining pins. Remove brake pads retaining spring clips. Compressing caliper pistons, remove brake pads.

2) Seat pistons in caliper bore with Piston Tool (2809). To avoid brake squealing, check piston position by installing Template (2919). Piston recess should incline 20 degrees in relation to lower guide area on caliper. See Fig. 1.

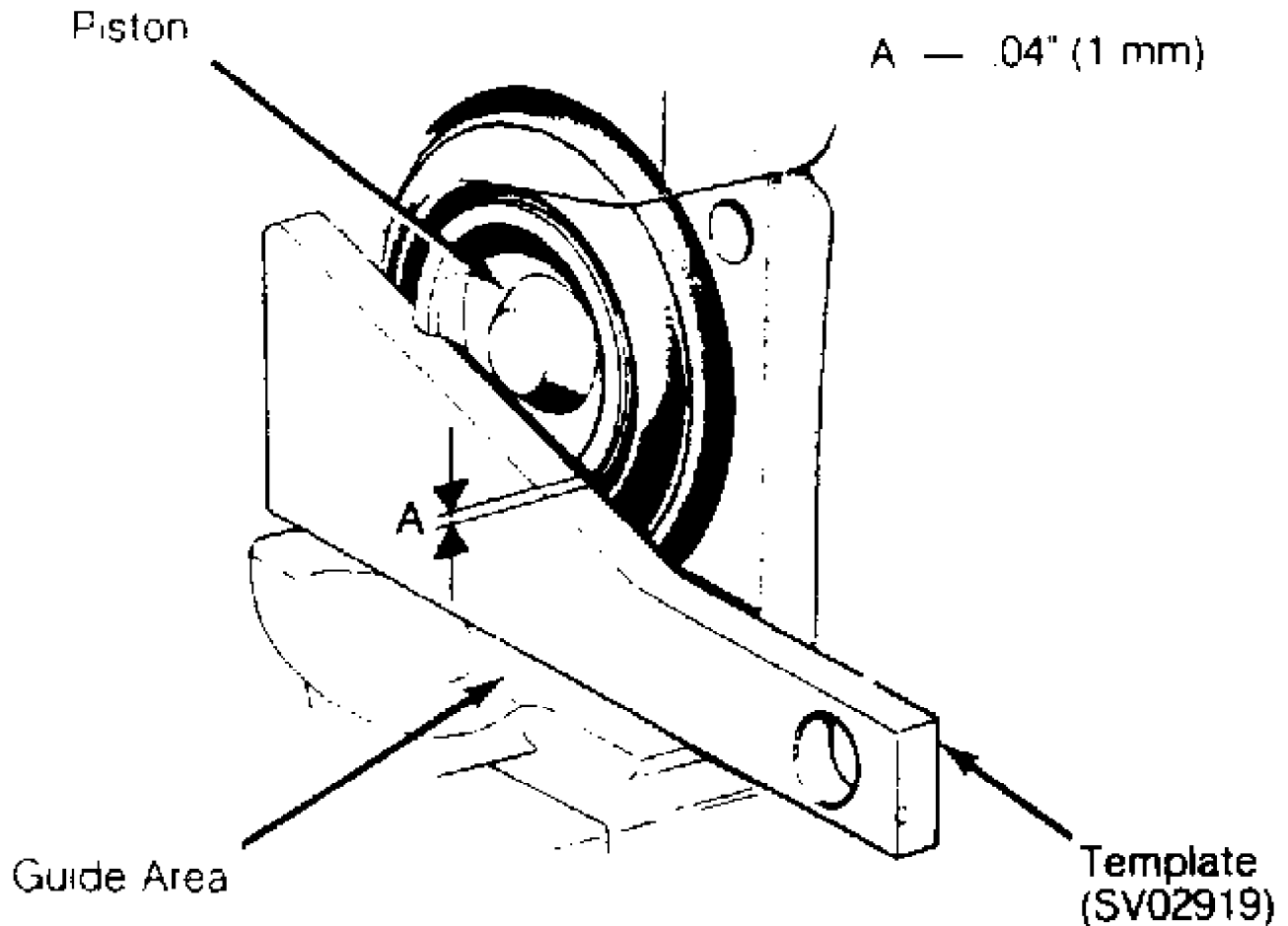

Fig. 1: Checking ATE Rear Caliper Piston Angle To Avoid Brake Squeal  
Courtesy of Volvo Cars of North America.

3) If distance from one piston recess to the other recess at measurement "A" exceeds .04" (1 mm), adjust piston position using Adjuster (2918) to rotate piston. See Fig. 1.

4) Install intermediate plates (if equipped) or damper washers (if equipped) in original positions. Install new brake pads and ALWAYS install new brake pad tensioning spring. Install and tap one retaining guide pin into position. Install new tensioning spring. Install other retaining guide pin while holding tensioning spring in

position.

**NOTE:** Install the damper washers with the small contact face toward pad. DO NOT install intermediate plates in calipers equipped with damper washers.

#### Bendix & Girling Pads

1) Raise and support vehicle. Mark position of wheel in relation to hub for reassembly reference. Remove tire and wheel. Loosen caliper upper guide pin bolt and remove caliper lower guide pin bolt only from brake pad holder assembly. Swing caliper upward and remove pads.

2) Compress caliper pistons. Inspect rubber guide pin covers and replace if defective. Install brake pads to holder and swing caliper into position. Ensure brake pad tension spring is in proper position. Tighten guide pin bolts to specification. Refer to TORQUE SPECIFICATIONS table at end of this article.

### CALIPER ASSEMBLY

#### Removal

Raise and support vehicle. Remove wheel. Disconnect brake line connections at caliper. Cap lines to prevent entry of foreign matter. Remove caliper mounting bolts. Lift caliper from mounting bracket.

#### Installation

1) Position caliper assembly on mounting bracket, and install attaching bolts. After installing bolts, check clearance between disc pads and rotor on both sides of rotor.

2) Maximum deviation between sides should not exceed .004" (.10 mm) on front calipers or .010" (.25 mm) on rear calipers. To adjust clearance, add shims to caliper. Connect hydraulic lines and bleed hydraulic system.

### FRONT DISC BRAKE ROTOR (740 & 760 SERIES)

1) Remove caliper. Remove hub cap. Remove cotter pin and castellated nut. Remove outer wheel bearing. Remove hub and rotor assembly.

2) To install, reverse removal procedure. Tighten castellated nut to 42 ft. lbs. (57 N.m). Back off nut. Tighten nut to 13 INCH lbs. (1.5 N.m). Install cotter pin.

### FRONT DISC BRAKE ROTOR (240 SERIES)

With caliper assembly removed, mount a dial indicator and check rotor runout. Runout must not exceed .004" (.10 mm). Measure rotor thickness through one revolution. Thickness variance must not exceed .0008" (.020 mm). Unscrew rotor lock bolts and pull rotor from hub. To install, reverse removal procedure.

### REAR DISC BRAKE ROTOR

Remove caliper. Remove screws retaining rotor to hub. Remove rotor. To install, reverse removal procedure.

### REAR AXLE SEAL & BEARING

**NOTE:** For information on models with sealed wheel bearings, see appropriate article:

- \* SUSPENSION - REAR - 1989
- \* SUSPENSION - REAR - 1990

#### Removal (240 Series)

1) Remove rear wheels and collision guards. Disconnect brake line and bracket from axle housing. Remove caliper and support to side with wire. Ensure parking brake is fully released. Remove brake rotor. Remove parking brake shoes, unhooking retaining springs.

2) Disconnect parking brake cables by driving out lock pin at lever. Remove bolts for bearing retainer through holes in axle flange. Remove axle shaft using Puller (2709). Pry inner seal from housing. Press bearing and snap ring off axle shaft. Remove oil seal.

#### Installation

1) Pack new bearing and new seal lip groove with high temperature wheel bearing grease. Place bearing retainer and oil seal on axle shaft. Press new bearing and new snap ring onto axle shaft. Narrow side of taper on snap ring fits into axle housing.

2) Install new inner seal. Install axle shaft. Tighten bearing retainer bolts. Install parking brake shoes. Reconnect cables. Install rotors. Check parking brake adjustment. Install brake caliper, pads, and collision guard (if equipped). Reconnect brake line and bracket to axle housing. Install wheels.

#### Removal (740 Series & 760 Series)

Remove cover at rear of center console. Remove adjusting screw by carefully tapping on spring sleeve with a hammer and screwdriver. Unscrew adjusting screw so that cables are loose. Raise vehicle. Remove rear wheels. Remove brake caliper and wire out of way. Remove brake rotor. Unhook rear return spring. Remove brake shoes.

#### Installation

Replace brake drum (rotor) if out-of-round exceeds .008" (.2 mm). Apply thin layer of heat resistant graphite grease on brake shoe contact surfaces. Assemble brake shoes. Install rear return spring. Using new bolts, install brake disc and caliper. Ensure that disc rotates without touching brake pads. Install wheels. Adjust parking brake cable. Lower vehicle.

## REAR WHEEL BEARING (760 SERIES)

#### Removal

1) Raise car and position rear lifting arms to avoid obstructing support arms. Remove brake caliper retaining bolts and tie up caliper to avoid damage to brake hose. Remove brake disc and mark position of disc in relation to guide pin. Remove brake pads. Disconnect handbrake cable from wheel bearing housing.

2) Remove bolt securing support arm to wheel bearing housing. Tap out arm. Remove bolt and nut securing lower link to wheel bearing housing. Remove track rod to wheel bearing housing securing bolt. Use small claw-type puller and M12 (50mm) bolt to withdraw track rod from wheel bearing housing.

3) Remove nut that secures drive shaft and nut that secures upper link to wheel bearing housing. Remove wheel bearing housing. Retain shims located between upper link and wheel bearing housing.

4) Position counterhold 5340 between hub and wheel bearing housing. Place wheel bearing housing in press and use drift 5088 to press off hub. Remove circlip retaining bearing in wheel bearing housing.

5) Use counterhold 5341 and drift 5085 to press bearing out of wheel bearing housing. Place drift on inner race. Use puller 2722 and counterhold 5310 to withdraw inner race from hub.

### Installation

1) Use drift 5242 and counterhold 5341 to press bearing on. Install circlip. Press on hub using drift 5088 and counterhold 5085.

CAUTION: Counterhold must be placed on inner race. If not bearing will be irreparably damaged.

2) Install wheel bearing housing on drive shaft, drive shaft nut, shims between upper link and wheel bearing housing, nut securing upper link to wheel bearing housing. Pull wheel bearing housing outwards at top edge and tighten upper link nut to 85 ft.lbs. (115 N.m).

NOTE: Ensure wheel alignment is correct after assembly.

3) Turn wheel bearing housing outwards and insert lower link. Insert bolts securing lower link. Pull wheel bearing housing inwards towards final drive. Tighten link to 37 ft.lbs. (50 N.m) and angle tighten through 90°.

4) Install support and tighten to 44 ft.lbs. (60 N.m) and angle tighten through 90°. Install track rod and tighten 63 ft.lbs. (85 N.m).

5) Install handbrake cable in wheel bearing housing, brake pads and brake disc per marking. Install brake caliper and tighten to 44 ft.lbs. (60 N.m). Lower car and tighten drive shaft nut to 103 ft.lbs. and angle tighten through 60°.

## PARKING BRAKE SHOES

### Removal (240 Series)

1) Remove center console rear ashtray. Loosen parking brake cable adjusting nut until cables are slack. Raise and support rear of vehicle. Remove wheels.

2) Remove caliper (without disconnecting hydraulic line) and support out of way. Remove rotor. Remove brake shoe return springs. Lift off shoes and adjuster. See Fig. 2.

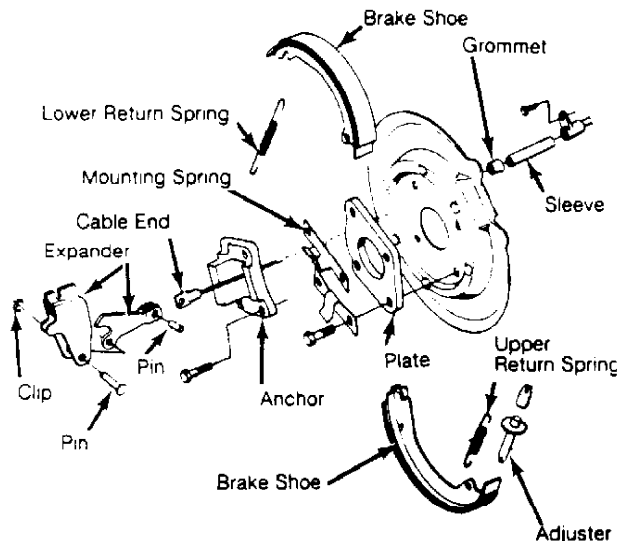

Fig. 2: Identifying Parking Brake Components  
Courtesy of Volvo Cars of North America.

### Installation

To install, reverse removal procedure. Replace brake drum

(rotor) if out-of-round exceeds .008" (.2 mm). Apply a thin coat of heat-resistant graphite grease to brake shoe sliding surfaces and to adjusting starwheel. Adjust starwheel until wheel starts to lock. Back off starwheel 4-5 notches. Ensure wheel rotates.

## MASTER CYLINDER

Disconnect hydraulic lines at master cylinder. Plug openings to prevent entry of foreign matter. Remove cylinder attaching nuts. Remove cylinder assembly from vehicle. To install, reverse removal procedure. Bleed hydraulic system. See BRAKE BLEEDING in this article.

## POWER BRAKE UNIT

Removal (740 Series & 760 Series)

1) Disconnect master cylinder and move it aside. Leave brake pipes attached to master cylinder. Disconnect vacuum hose. Using screwdriver, pry check valve from unit. Remove fuel filter and move it aside.

2) Disconnect vacuum pump and move aside. Remove soundproofing on left side of center console. Disconnect push rod from brake pedal. Remove 4 power brake unit retaining nuts and power brake unit. Remove check valve seal.

Installation

Install seal in power brake unit. Ensure seal is correctly seated. Remove Sealing Ring (1272078-5) and install on new power brake unit. To complete installation, reverse removal procedure.

Removal (240 Series)

Remove master cylinder. Disconnect vacuum hose. Remove soundproofing on left side of center console. Disconnect pressure rod from brake pedal. Remove power brake unit.

Installation

Apply sealing compound to contact surface on firewall. Fit other types with sealing ring. Reverse removal procedure to complete installation.

## CHECK VALVE REPLACEMENT

Disconnect vacuum hose from check valve. Using 2 screwdrivers, lever out check valve. Remove seal. Install new seal, ensuring that flange is properly aligned in cylinder. Coat seal with grease. Press valve carefully into place. Ensure that seal does not move out of position. Reconnect vacuum hose so that highest point is attached to valve.

## OVERHAUL

### BRAKE CALIPER

Disassembly

Remove disc pads, piston dust covers, and retaining clips. Insert wooden block into caliper housing. Apply compressed air at fluid inlet ports to force pistons out of caliper. Remove piston seals from cylinder bore.

NOTE: DO NOT separate caliper halves.

Cleaning & Inspection

Clean all parts in brake fluid or alcohol. Inspect cylinder bores for scoring, rust or corrosion. Replace if defective. Replace rubber seals and dust covers during overhaul. See Figs. 3-6.

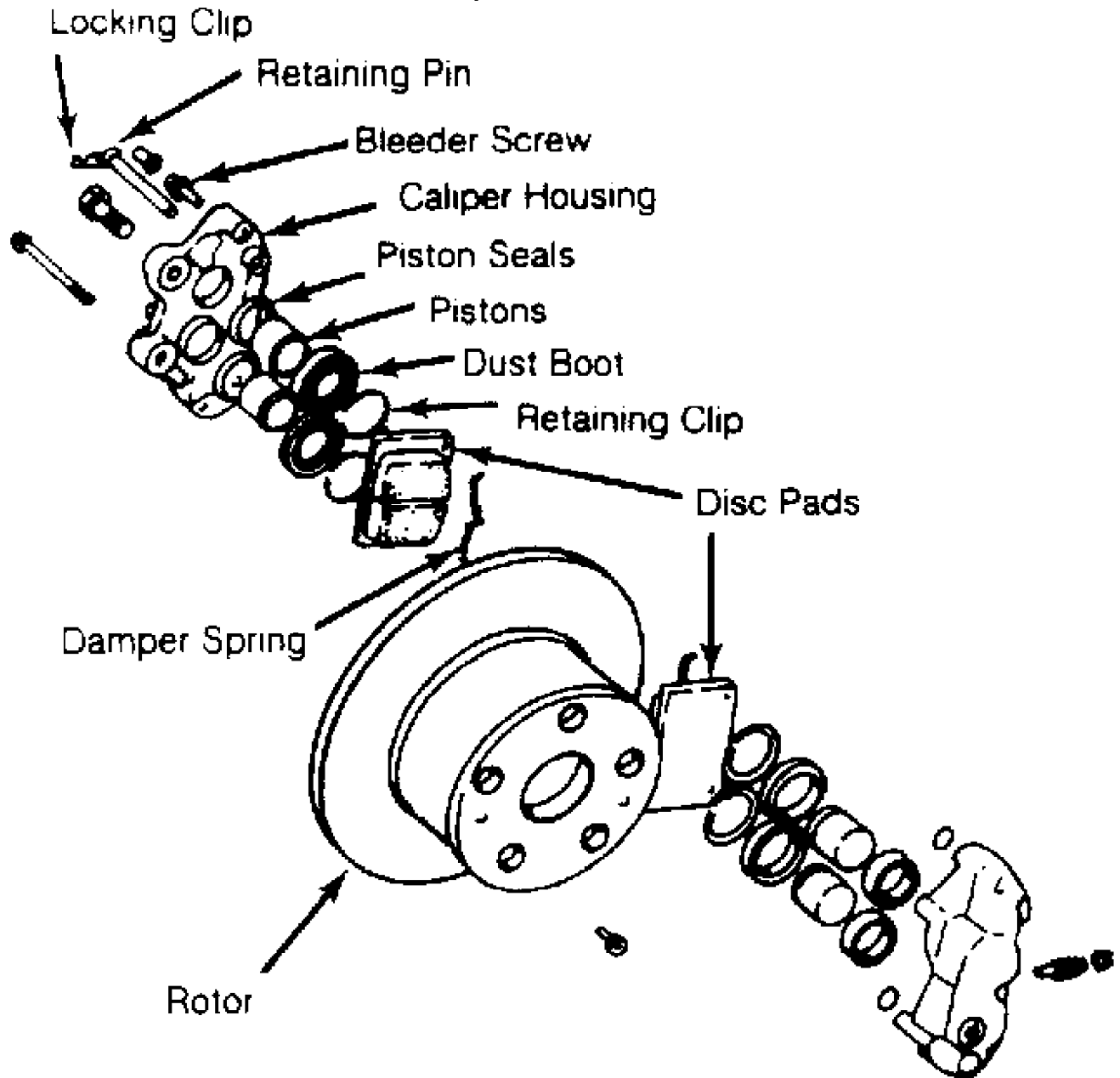

Fig. 3: Identifying Girling Front Caliper Components  
Courtesy of Volvo Cars of North America.

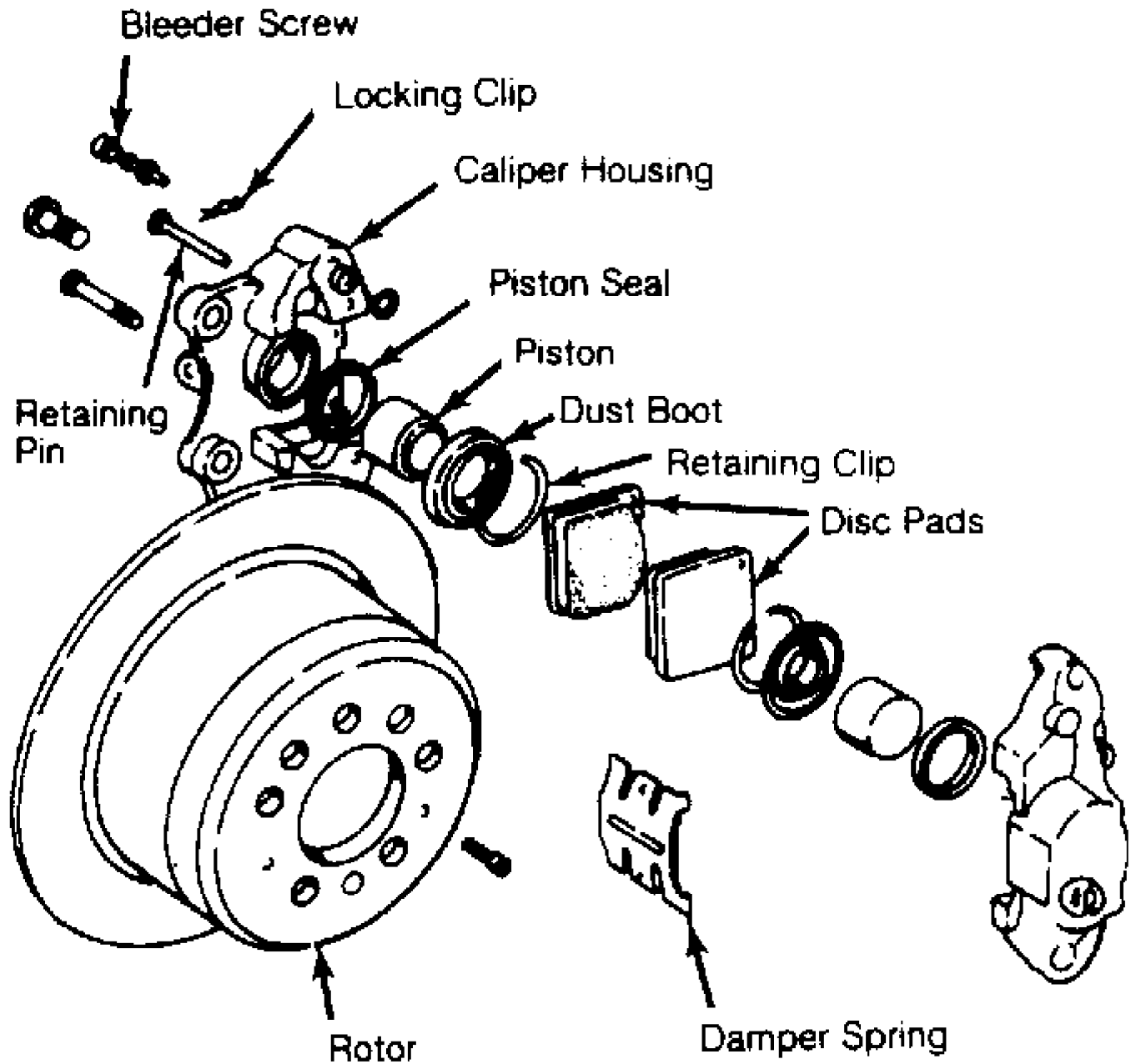

Fig. 4: Identifying Girling Rear Caliper Components  
Courtesy of Volvo Cars of North America.

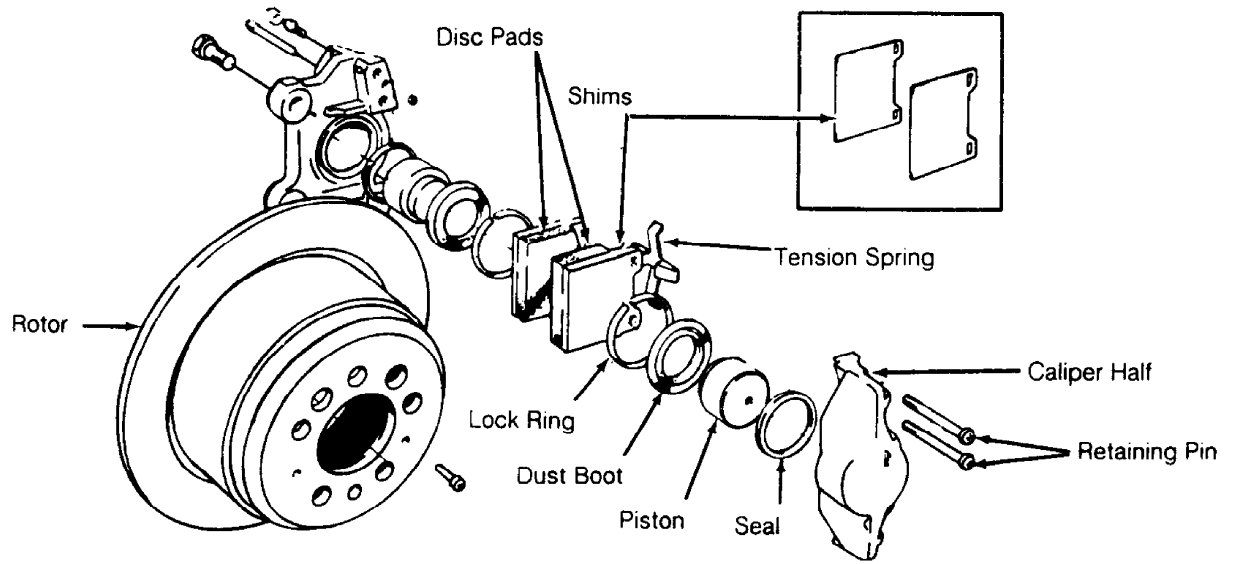

Fig. 5: Identifying ATE Rear Caliper Components  
 Courtesy of Volvo Cars of North America.

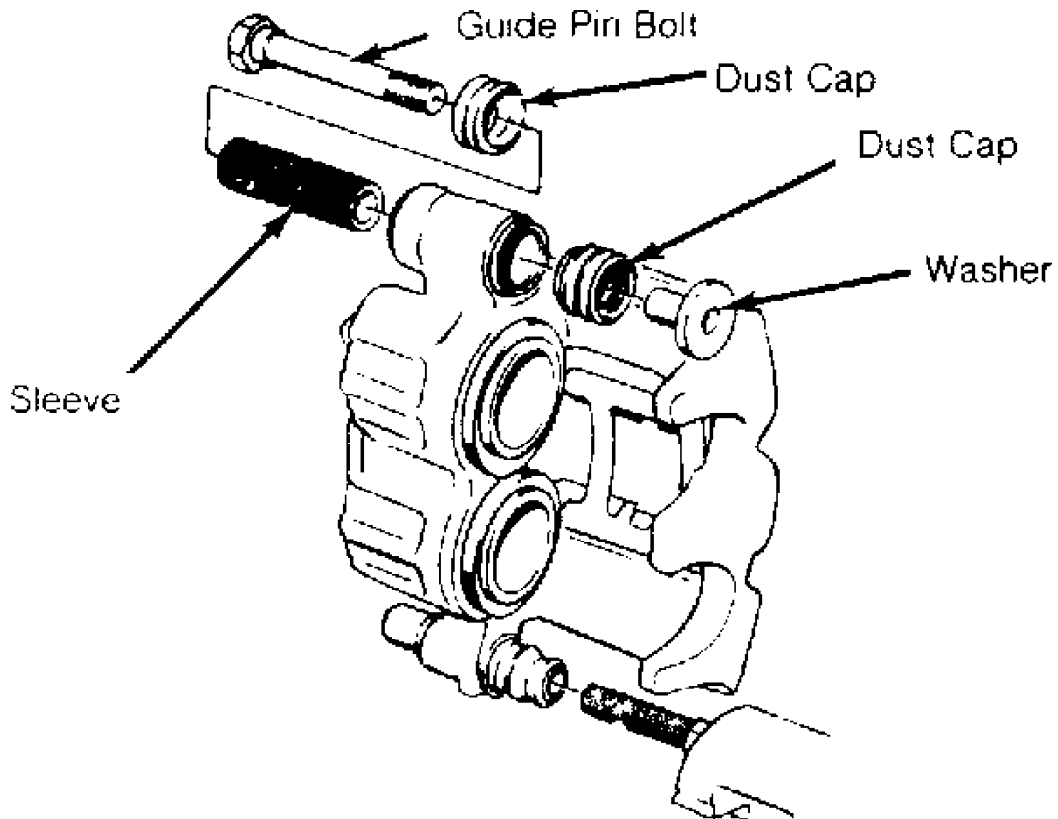

Fig. 6: Identifying Bendix (DBA) Front Caliper Components  
 Courtesy of Volvo Cars of North America.

Reassembly  
 Coat all parts with clean brake fluid. Install new piston

seals in cylinder bores. Carefully install pistons into cylinder bores. On ATE rear brake calipers, check piston position. Refer to DISC PADS under REMOVAL & INSTALLATION in this article. Refer to Fig. 1. Install dust boots and retaining clips. Install bleeder screw and disc pads.

## MASTER CYLINDER

### Disassembly

Remove master cylinder from vehicle. Clamp mounting flange in a vise. Remove reservoir from cylinder. Remove rubber sealing rings. Remove retainer ring from end of cylinder bore. Remove pistons from cylinder bore. See Fig. 7.

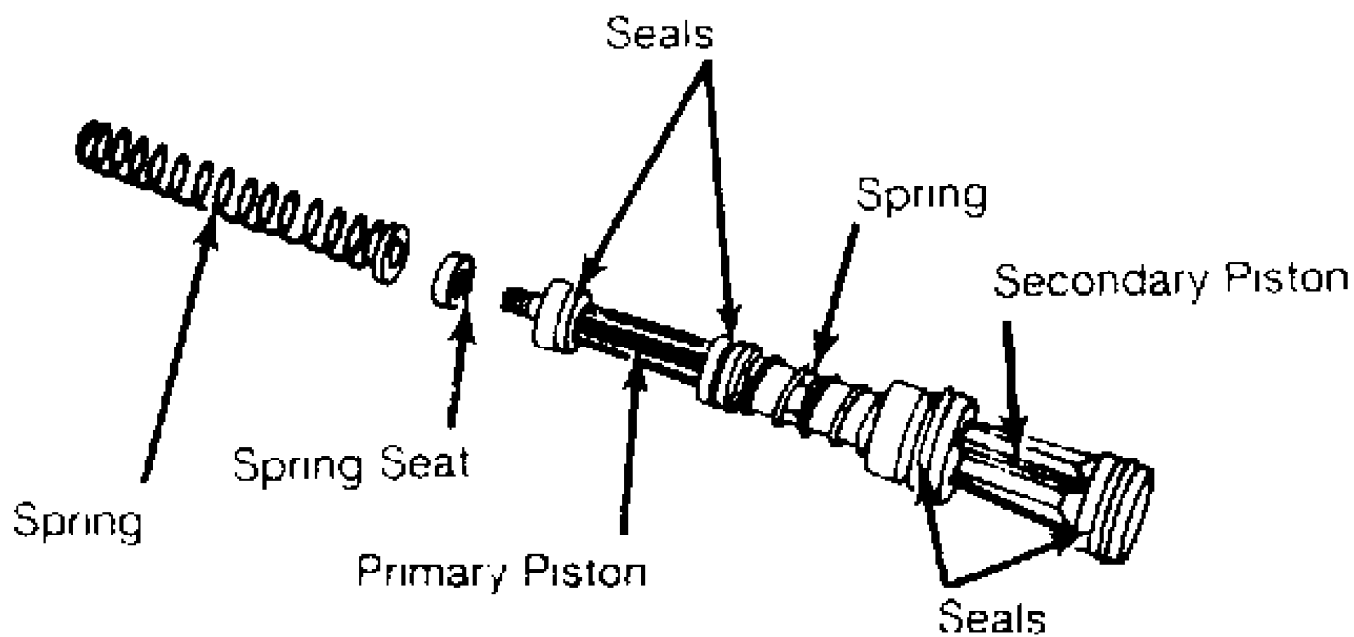

Fig. 7: Identifying Master Cylinder Piston Components  
Courtesy of Volvo Cars of North America.

### Cleaning & Inspection

Wash all parts in clean brake fluid or alcohol. Blow dry with compressed air. Inspect cylinder bore for scratches, rust or corrosion. Replace if defective. Replace both pistons with connector sleeve as an assembly.

### Reassembly

1) Lubricate all parts with clean brake fluid prior to reassembly. Position washer, seal, and back-up ring on secondary piston. Install spring thrust washer on piston. Install piston assembly into cylinder bore. Install washer, seal and back-up ring on primary piston.

2) Install spring with plate and sleeve on piston. Install piston assembly into cylinder bore. Push piston into cylinder bore. Install retaining ring. Install reservoir sealing rings, and install reservoir.

## TORQUE SPECIFICATIONS

TORQUE SPECIFICATIONS

---

| Application                          | Ft. Lbs. (N.m)  |
|--------------------------------------|-----------------|
| Caliper Guide Pin Bolts .....        | 25 (34)         |
| Front Caliper Mounting Bolts .....   | 74 (100)        |
| Master Cylinder Mounting Bolts ..... | 22 (30)         |
| Rear Caliper Mounting Bolts .....    | 43 (58)         |
| Wheel Lug Nuts                       |                 |
| 740 Series & 760 Series .....        | 63 (86)         |
| 240 Series .....                     | 85 (116)        |
|                                      | INCH Lbs. (N.m) |
| Rotor Retaining Stud .....           | 72 (8)          |

---

## DISC BRAKE SPECIFICATIONS

### 240 SERIES

#### DISC BRAKE SPECIFICATIONS

---

| Application                            | In. (mm)    |
|--|-------------|
| Disc Diameter                          |             |
| Front                                  |             |
| Solid .....                            | 10.33 (263) |
| Vented (ATE) .....                     | (1)         |
| Vented (Girling) .....                 | (1)         |
| Rear .....                             | 11.06 (281) |
| Lateral Runout (Maximum)               |             |
| Front & Rear .....                     | .004 (.10)  |
| Original Thickness                     |             |
| Front                                  |             |
| Solid .....                            | .563 (14.3) |
| Vented (ATE) .....                     | (1)         |
| Vented (Girling) .....                 | (1)         |
| Rear (Solid) .....                     | .38 (9.6)   |
| Minimum Refinish Thickness .....       | (2)         |
| Discard Thickness                      |             |
| Front                                  |             |
| Solid .....                            | .500 (12.7) |
| Vented (ATE) .....                     | .90 (22.8)  |
| Vented (Girling) .....                 | .80 (20.4)  |
| Rear .....                             | .33 (8.4)   |
| Parking Brake Drum (Inside Rotor)      |             |
| Maximum Diameter .....                 | (1)         |
| Maximum Runout .....                   | (1)         |
| Master Cylinder Diameters              |             |
| Primary .....                          | .88 (22.3)  |
| Secondary .....                        | .62 (15.75) |
| Rear Brake Caliper Pistons (ATE) ..... | 1.5 (38)    |

(1) - Information not available.

(2) - Always use minimum thickness specification stamped on rotors.

---

### 740 SERIES & 760 SERIES

#### DISC BRAKE SPECIFICATIONS

---

| Application | In. (mm) |
|-------------|----------|
|-------------|----------|

|                                   |       |               |
|-----------------------------------|-------|---------------|
| Disc Diameter                     |       |               |
| Front                             |       |               |
| Solid                             | ..... | 11.02 (280)   |
| Vented                            | ..... | 11.02 (280)   |
| Rear                              | ..... | 11.06 (281)   |
| Lateral Runout (Maximum)          |       |               |
| Front                             | ..... | .002 (.06)    |
| Rear                              | ..... | .003 (.08)    |
| Original Thickness                |       |               |
| Front                             |       |               |
| Solid                             | ..... | .55 (14.0)    |
| Vented (ATE)                      | ..... | .87 (22.1)    |
| Vented (Girling)                  | ..... | 1.02 (26)     |
| Rear                              | ..... | .38 (9.6)     |
| Minimum Refinish Thickness        |       |               |
| Discard Thickness                 |       |               |
| Front                             |       |               |
| Solid                             | ..... | .433 (11.0)   |
| Vented (ATE)                      | ..... | .79 (20.0)    |
| Vented (Girling)                  | ..... | (1)           |
| Rear                              | ..... | .315 (8.00)   |
| Parking Brake Drum (Inside Rotor) |       |               |
| Maximum Diameter                  | ..... | 6.32 (160.45) |
| Maximum Runout                    | ..... | .006 (.15)    |
| Master Cylinder Diameters         |       |               |
| Primary                           | ..... | .94 (23.8)    |
| Secondary                         | ..... | .66 (16.8)    |
| Rear Brake Caliper Pistons (ATE)  | ..... | 1.5 (38)      |

(1) - Information not available.

(2) - Always use minimum thickness specification stamped on rotors.